

# **GUEST**

## **MODEL 729492**

DUAL STATION  
FOR 298-57-24 AND 503-2 SPOT/FLOOD  
WIRED REMOTE LIGHT

INSTALLATION AND OPERATION  
INSTRUCTIONS

### **IMPORTANT !**

READ THESE INSTRUCTIONS BEFORE  
INSTALLING AND USING THIS PRODUCT.

This Wired Dual Station is designed for use with Guest Models 298-57-24 and 503-2, Eight-Wire Remote Spot/Flood lights. The following instructions will easily allow you to integrate this dual station into your existing Control Panel/Spotlight installation.

1. Surface mount the secondary control panel to any convenient surface.

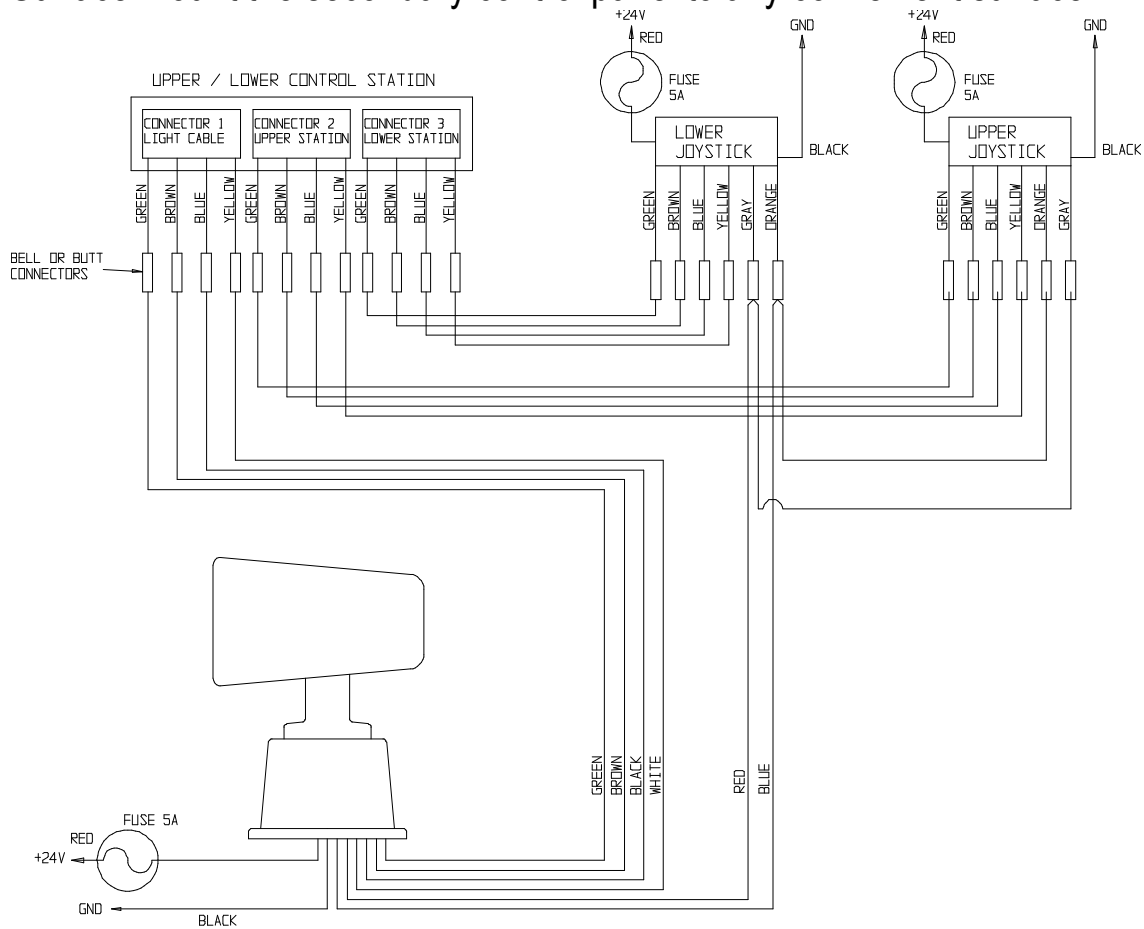

2. Connect the wires from the light, existing control panel, and dual station control and selector station as shown:

CONTROL PANELS

LIGHT

1. Cable

Cable

Connect the wires from the four cables (Light, Existing Control Panel, Dual Station, and Selector Station) by matching the colors.

2. Black – Neg. Batt. (Grd.)

Black – Neg. Batt. (Grd.)

3. Red – Pos. Batt. (+24V)

Red – Pos. Batt. (+24V)

3. You are now ready to operate the light.

## LIMITED WARRANTY

For one (1) year from the date of original purchase, The Guest Co. will, at its discretion, repair or replace for the original consumer, free of charge, any part or parts found defective in material or workmanship. All transportation charges under this warranty must be borne by the consumer.

Proof of purchase is required. A computerized register receipt is required. Handwritten receipts are not accepted for warranty proof of purchase. In the absence of a receipt, warranty period will be calculated from date of manufacture printed or stamped on the product.

THERE IS NO OTHER EXPRESSED WARRANTY. IMPLIED WARRANTIES, INCLUDING THOSE OF MERCHANTABILITY AND FITNESS FOR A PARTICULAR PURPOSE, ARE LIMITED TO ONE YEAR FROM THE DATE OF PURCHASE. THIS IS THE EXCLUSIVE REMEDY AND CONSEQUENTIAL DAMAGES ARE EXCLUDED WHERE PERMITTED BY LAW.

## CUSTOMER SERVICE

If you, our customer, have any questions concerning Guest products, parts or warranties, please contact our Service Department Monday through Friday between 11:00 AM and 7:00 PM Eastern Time.

Tel: (707) 226-9600  
Fax: (707) 226-9670

Email: [info@marinco.com](mailto:info@marinco.com)  
Website: [www.marinco.com](http://www.marinco.com)